



MGU200-MGG200

SDI multiview building block with 8 inputs and up to 8 outputs (heads) or dual 4k/UHD output resolution

A Synapse® product

**Modular
Multiview**

3 TRIPLE RATE
Gb/s, HD, SD

**4K
ULTRAHD**
3840 x 2160

 **Powered
by LINUX**

3Gb/s
Level B
compliant

COPYRIGHT © 2018 AXON DIGITAL DESIGN BV

ALL RIGHTS RESERVED

NO PART OF THIS DOCUMENT MAY BE REPRODUCED IN ANY FORM WITHOUT THE PERMISSION OF AXON DIGITAL DESIGN BV.

Introduction

SynView is Axon’s next generation Synapse modular multi-viewer. The system consists of 6 different models. These models can be mixed and matched to build a hybrid multiviewer with up to hundreds of inputs and 8 1080p heads (on SDI) or two heads with UHD/4K resolution. Multiple connector panels will be available to allow for different I/O configurations.

There currently are 6 models defined:

differentiation Model name Application	SDI IN	SDI OUT	IP inputs (physical)	IP inputs (logical)	IP outputs	PIP	monitoring
MGU200 Production SDI inputs	8	8	-	-	-	16	basic
MGG200 Production SDI inputs	8	2	-	-	-	16	basic
MGU100 Monitoring SDI inputs	8	8	-	-	-	8	extensive
MGG100 Monitoring SDI inputs	8	2	-	-	-	8	extensive
MNU100 Network IP inputs	-	8	2x6 Back-up redundancy	6	-	6	basic
MNG100 Network IP inputs	-	2	2x6 Back-up redundancy	6	-	6	basic

The above cards have the same output configuration with up to dual head UHD/4k on dual quad 3Gb/s SDI, or 8 heads on SDI. The cards can be combined in any combination up to **12** cards in the new SFR18 gen3 with the new SMP175 power supply. In the Gen3 SFR08 will fit up to 5 boards.

Because of the external Daisy Chain mini SAS-HD connector you can build a multi viewer with, in theory, an unlimited amount of input channels as you can chain the cards even between frames. You can split the multiviewer into smaller chunks of cards, each block with its own set of PIPs (Picture In Pictures) and its own outputs. A MGU200 can also be used stand alone as a dual quad split (or even oct split) with 8 1080p pictures spread over 2 UHD screens (pixel mapping with no scaling)



Block schematic MGU200 & MGG200

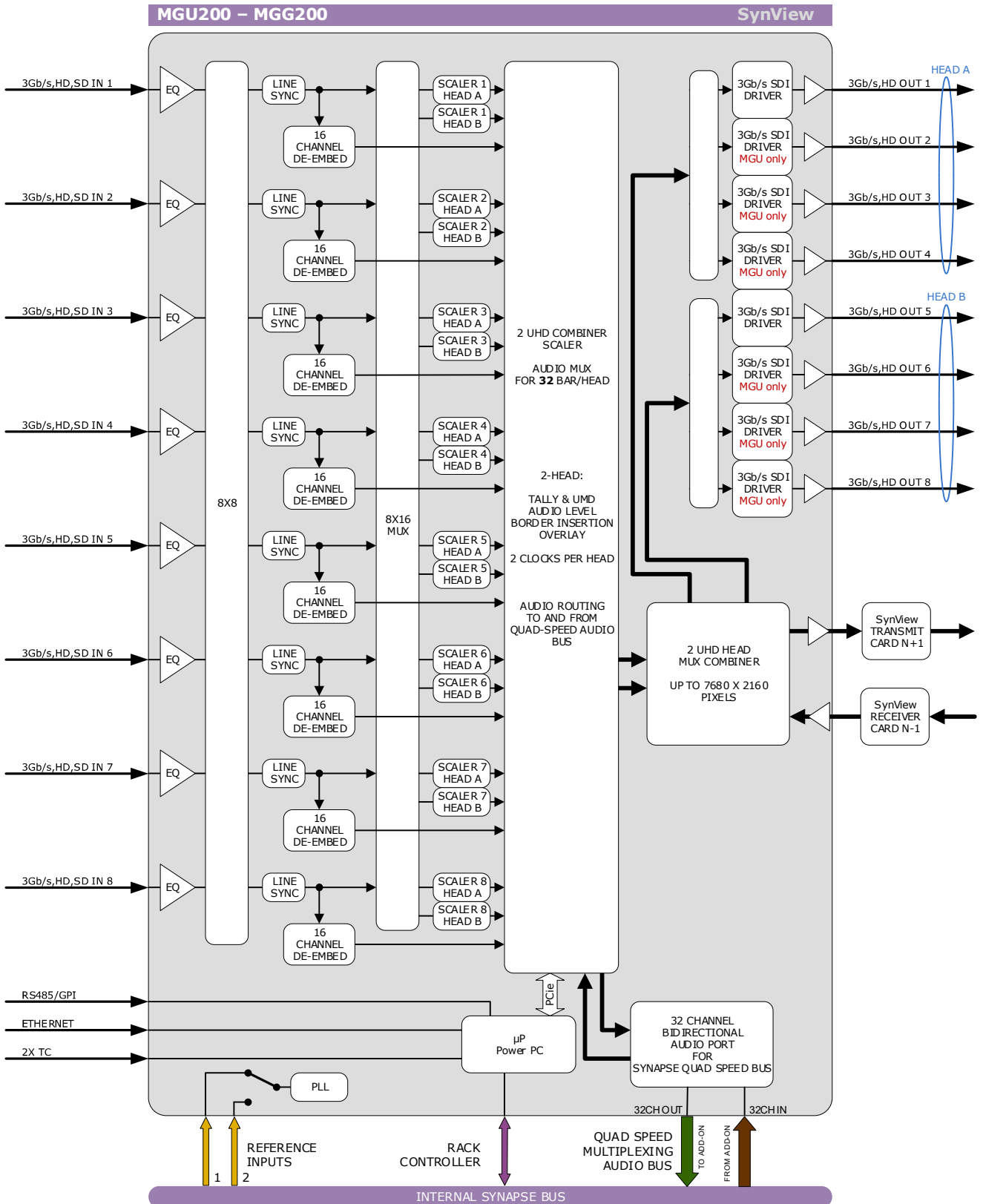

Connector panel option

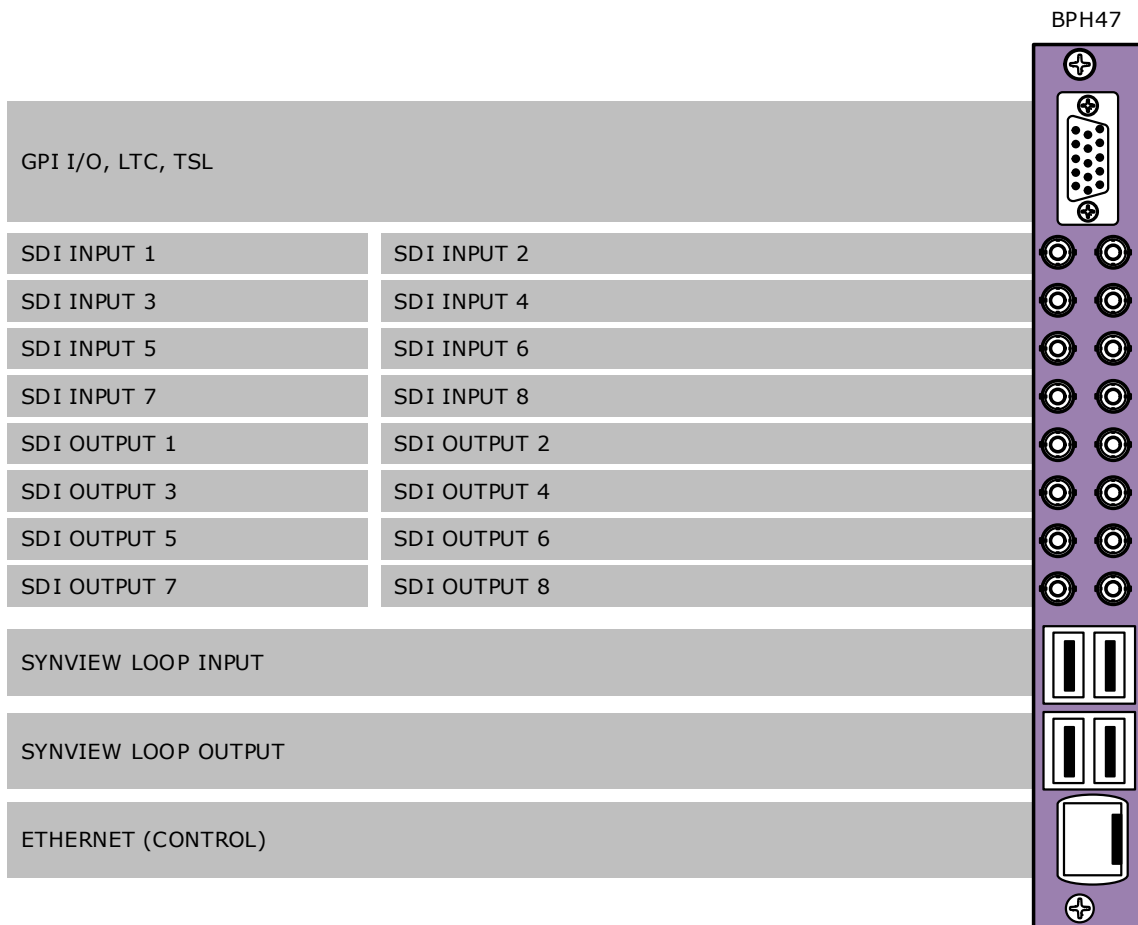

HDMI connectivity

The consumer display market supplies our industry with great monitor options at very reasonable prices. The UHD compatibility of Synview2 allows for the use of very cost effective 4k UHD screens. The inputs for these screens are always based on HDMI. Recently the standard has been improved and the 2.0 spec allows for 4k with up to 60p frame rates.

A four wire to HDMI 2.0 converter ideally compatible with 2SI (or two sample interleaved) or Quadrants is needed to connect the SDI outputs to these commercial screens.

Features

The MGU200, MGG200, MGU100, MGG100 and MNU100 are all based on the same hardware. Via different firmware and selected connector panels, you can build a vast array of multiview application by mixing and matching the different versions

Features MGU200/MGG200:

- 8 inputs to two individual panel outputs or 8 SDI outputs (MGU200) or 2 SDI (up to 1080p) outputs (MGG200)
- Each input can be displayed on each head with an individual scale and position
- Low latency (20 ms for 50Hz, 17 ms for 59.94Hz)
- Full RGB domain (internal 20bit processing for scaling)
- Up to 2x 4k/UHD (2160p60) resolution on 2x 4-wire SDI (MGU200 only)
- Up to 8 3Gb/s SDI outputs
- Full variable scaling and positioning for all individual inputs
- All inputs are compatible with 1080p50/59.94, 1080p(sf)29.97/25/24, 1080i50/59.94, 720p59.94/50/29.97/25/24 and SD625/525 (mixing is allowed with different frame rates)
- 32 audio bars (per head) free assignable from 128 embedded sources and/or 32 sources via the Quad Speed Audio bus
- Three assignable regions in or under monitor: Input format, Static UMD and Dynamic UMD, VITC, ATC, LTC, Aspect Ratio
- Lock to input, reference or free running
- Masked or transparent audio bar graphics with AES/EBU, BBC or Nordic scale VU meters.
- Customizable color schemes for audio meters
- Two definable clocks per head; Analog, Digital or Combined
- Digital clock can be set to normal time, up counter or down counter
- Clocks can be assigned to VITC, ATC, LTC, NTP (Ethernet) or system
- UMD colors: gray, green, red and amber
- Border, UMD and tally brightness adjustments
- Automatic 4:3 and 16:9 modes through VI or WSS triggers (SD-SDI inputs)
- GPI control for Aspect ratio, Full screen modes and Tally
- Locks to Bi-level, Tri-level syncs or SDI input
- Full control and status monitoring through the front panel of the SFR08/SFR18 frame and the Ethernet port (ACP)

For more information, screen examples and explanations about the various I/O modes, please refer to the Synview brochure via our website www.axon.tv/synview.

Applications

- Small to extremely large monitoring walls
- Fast response production monitor walls with unequalled low processing delay and startup time
- High resolution high source count monitor walls
- OB van preview monitoring and shading

Ordering information

Module:

- **MGU200:** 8 x SDI input with 16 PIPs and dual UHD head
- **MGG200:** 8 x SDI input with 16 PIPs and dual HD head

Standard I/O:

- **BPH47_MGXxxx:** Connector panel for SDI inputs

Specifications

Serial Video Input

Standard	625/50 or 525/59.94 SMPTE 259M-C (270Mb/s) with SMPTE 272M embedded audio SMPTE 292M (1.5Gb/s), SMPTE 260M, SMPTE 274M, SMPTE 296M, SMPTE 349M, SMPTE424 1080i/59.94, 1080i/50, 720p/59.94, 720p/50 1080p/50 and 1080p/59.94
Equalization	Automatic to 100m @ 1.5Gb/s with Belden 1694A or equivalent cable. Automatic to 80m @ 3Gb/s with Belden 1694A or equivalent cable.
Return Loss	> 15dB up to 1.5GHz
Number of Inputs	8

Reference Input through RRC

Number of Inputs	2 on SFR18, 2 on SFR08
Tri-level	SMPTE274M, SMPTE296M 600 mVp-p nominal, 75 Ohms terminated through loop
Bi-level	PAL Black Burst ITU624-4/SMPTE318, Composite NTSC SMPTE 170M 1Vp-p nominal, 75 Ohms terminated through loop

Display output

Standard	RJ45 containing DVI or HDMI up to UHD/60p
Number of Outputs	2 display signals Up to 8 3Gb/s SDI
Cable driver	Up to 10 meter with CAT6 Up to 100 meter on SDI

Serial video output

Standard	SMPTE 292M (1.5Gb/s), SMPTE 260M, SMPTE 274M, SMPTE 296M, SMPTE 349M, SMPTE424A
Number of Outputs	8

LTC Input

Standard	SMPTE 12M
Connector	15pins D-sub
Number of Inputs	2

Miscellaneous

Weight	Approx. 350g
Operating Temperature	0 °C to +50 °C
Dimensions	137 x 296 x 20 mm (HxWxD)

Electrical

Voltage	+24V to +30V
Power	<35 Watts